



OPTICAL COMPONENTS TRANSACTION



PIRELLI SPA: BUSINESS STRUCTURE

Half Year 2000 Sales (Euro mn)

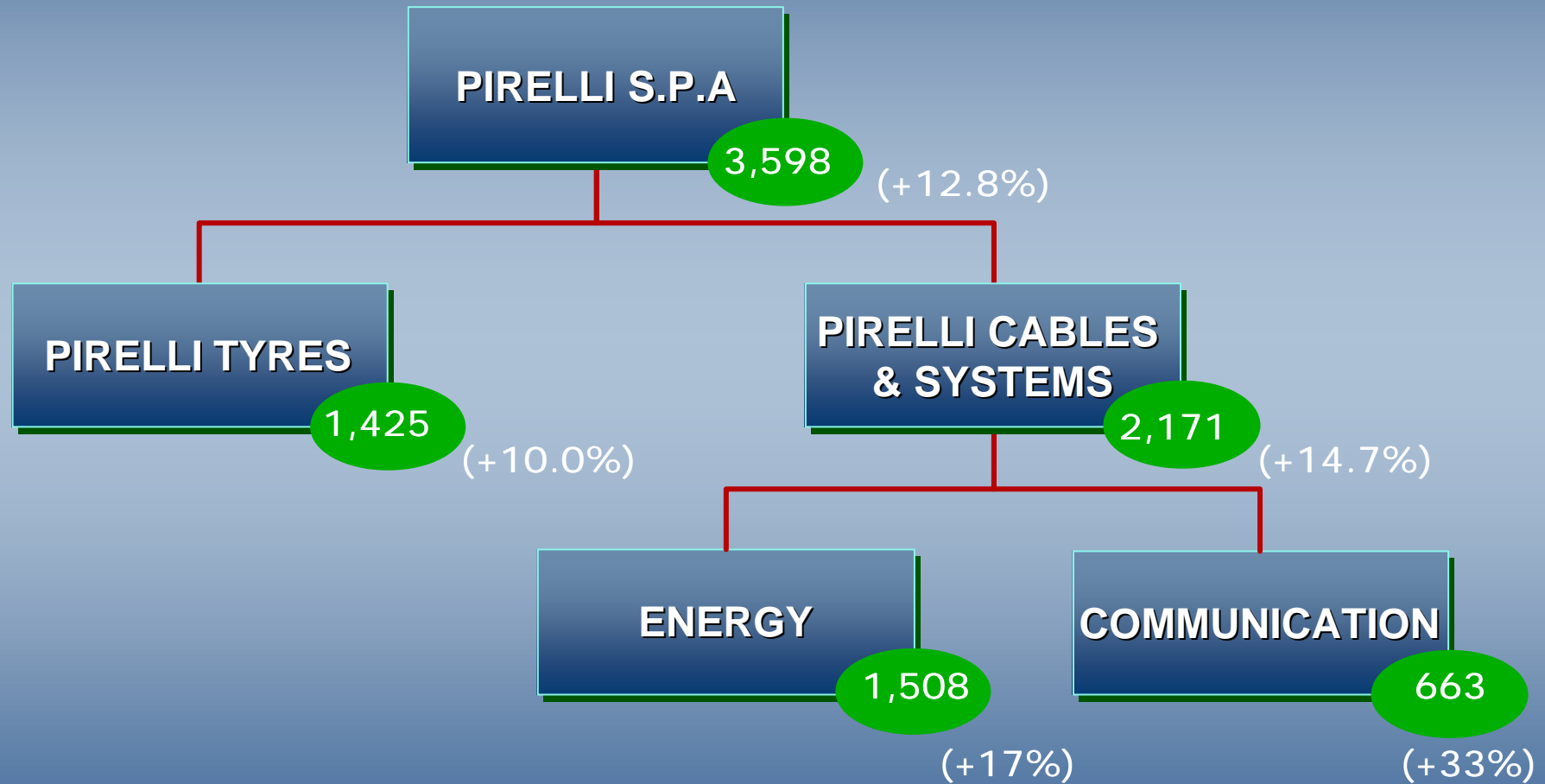

PIRELLI GROUP

THREE BUSINESSES - THREE STRENGTHS

Communications

- ? Leading-edge technology in fiber optics, optical cables and submarine optical systems
- ? Investment in fiber optic production capacity under way
- ? Opportunities in the development of internet infrastructure

Energy

- ? **World No. 1**
- ? **Technology innovator**
- ? **Cost leader**
- ? **Business growth driven by economic development and environmental trends**

Tyre

- ? **Global full range player**
- ? **Leading UHP producer**
- ? **Revolutionary MIRS process**
- ? **E-tyre/ Cyber-tyre potential**

CABLES AND SYSTEMS: COMMUNICATION BUSINESS

Sector sales (Euro mn)

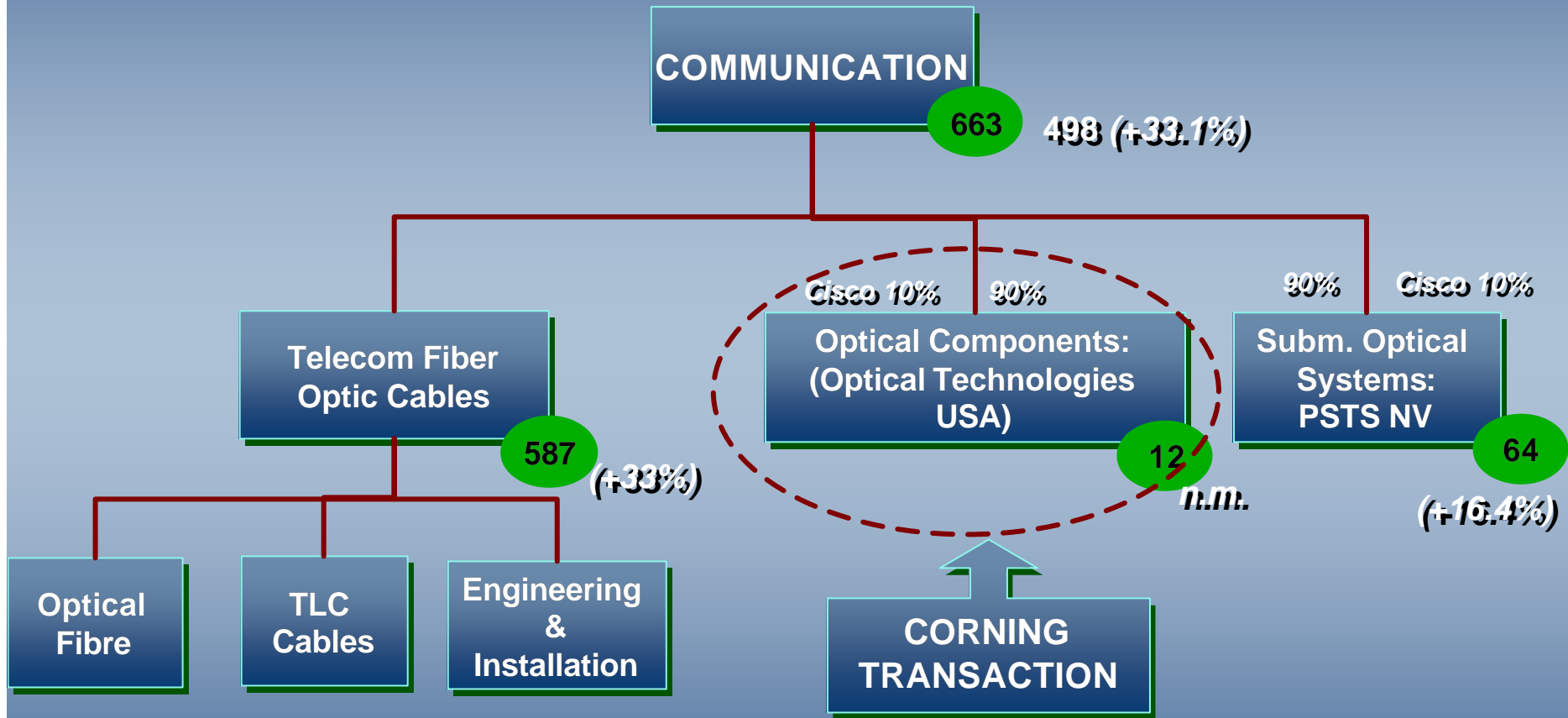

OPTICAL COMPONENTS PROFILE

Technology

Components

 LiNbO₃



Modulators

 GaAs



Pump lasers

 Fiber Gratings



Filters
Dispersion
Compensators

 Special
Fibers



Active and
special
designed fibers

FINANCIALS (1H 2000, mn US €)

Revenues: 12 mn (Forecast 2000 ~ 28 mn €)

EMPLOYEES (end of September 2000)

TOTAL: ~ 360
1/3/2000 (start-up) ~ 166



OPTICAL COMPONENTS TRANSACTION CONSIDERATION FOR PIRELLI

? TRANSACTION:

• Sale to Corning:

- share capital of Optical Technologies USA for USD 3.9 bn (Pirelli holds 90% of the capital, Cisco 10%)
- other assets held by Pirelli Cavi e Sistemi for USD 100 mn

? VALUATION: - Revenue Multiple (CY 2000 E)

	Current Transaction	Market Leaders
	165.3 X	25.0 X

? CONSIDERATION FOR PIRELLI :

(most important telecommunication
cash transaction)

- initial cash consideration:	USD 3.43 bn	} Total 3.61 bn
- Earn-out:	USD 0.18 bn	
- Net proceeds:	USD 3.05 bn	

? TIMING:

- Binding Agreement 26/09/2000
- Antitrust Authority approval obtained on 25/10/2000
- Closing expected for Mid-December

